

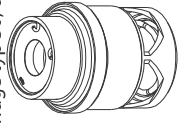

ALPHA Cartridges

Cartridge typ 50, 60



Cartridge typ 30, 40

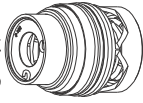

Cartridge typ 10, 11, 20

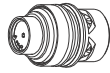

Female/Female	ALPHA DN15-25	25 - 2.448 l/h			
	ALPHA DN25L-50		677 - 11.354 l/h		
Fixed end female/union	ALPHA DN15-25	25 - 2.448 l/h			
	ALPHA DN25L-40		677 - 11.354 l/h		
For unions with actuator	EVA DN15/20/25	25 - 2.448 l/h			
	EVA BASIC DN15	25 - 2.448 l/h			
For Flanges	ALPHA DN50			3.820 - 45.000 l/h	
	ALPHA DN65			3.820 - 45.000 l/h	
	ALPHA DN80			3.820 - 45.000 l/h	
For Flanges	ALPHA DN100			3.820 - 90.000 l/h	
	ALPHA DN125			3.820 - 135.000 l/h	
For Flanges	ALPHA DN150			3.820 - 180.000 l/h	
	ALPHA DN200			3.820 - 315.000 l/h	
For Flanges	ALPHA DN250			3.820 - 540.000 l/h	
	ALPHA DN300			3.820 - 675.000 l/h	
For Flanges	ALPHA DN350			3.820 - 855.000 l/h	
	ALPHA DN400			3.820 - 1.170.000 l/h	
For Flanges	ALPHA DN450			3.820 - 1.485.000 l/h	
	ALPHA DN500			3.820 - 1.800.000 l/h	
For Flanges	ALPHA DN600			3.820 - 2.520.000 l/h	
	ALPHA DN800			3.820 - 3.825.000 l/h	

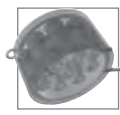

ALPHA Cartridges

Application

ALPHA Cartridges is used in heating and cooling systems for the distribution of flow in various sections of the system.

The dynamic balancing valve ensures easy and reliable balancing of the system, regardless of any fluctuations in the differential pressure of the system.

ALPHA Cartridges limits maximum flow in the system, and ensures the most economical operation.

Can be used in both variable and constant flow systems.

From small size valves (DN15) to big wafer types (DN800), there is a ALPHA Cartridge that guarantee the specified flow.

Benefits

- Quick and easy selection as only flow data are required.
- Security that the specified flow will not be exceeded.
- Easy to install according to pre-defined flow.
- Minimized commissioning time due to automatic balancing of the system.
- High comfort for the end-users due to right balance of the hydraulic system.
- The valves automatically find the hydraulic balance regardless of pressure fluctuations in the system.
- No main circuit or branch balancing valves needed in the system.
- Improved response to water hammer due to the chock absorption by the rubber diaphragm of the cartridge.



Features

- Removable cartridge solution simplifies flushing procedure
- No minimum straight pipe lengths required before or after the valve.
- Built-in optional P/T plugs for needle system.
- Minimized friction and noise due to the patented cartridge design based on the metal-rubber diaphragm-metal contact.



ALPHA Cartridges

Function ALPHA

The following applies to all flow control valves:

$$Q = K_v * \sqrt{\Delta p}$$

Q = Flow (m³/h)

K_v = Opening area

Δp = Differential pressure (Bar)

The ALPHA cartridges, react to pressure fluctuations so that the differential pressure across the pre-adjustment unit is kept constant.

In that way a max. flow limit is ensured in accordance with the design.

Simplified outline ALPHA

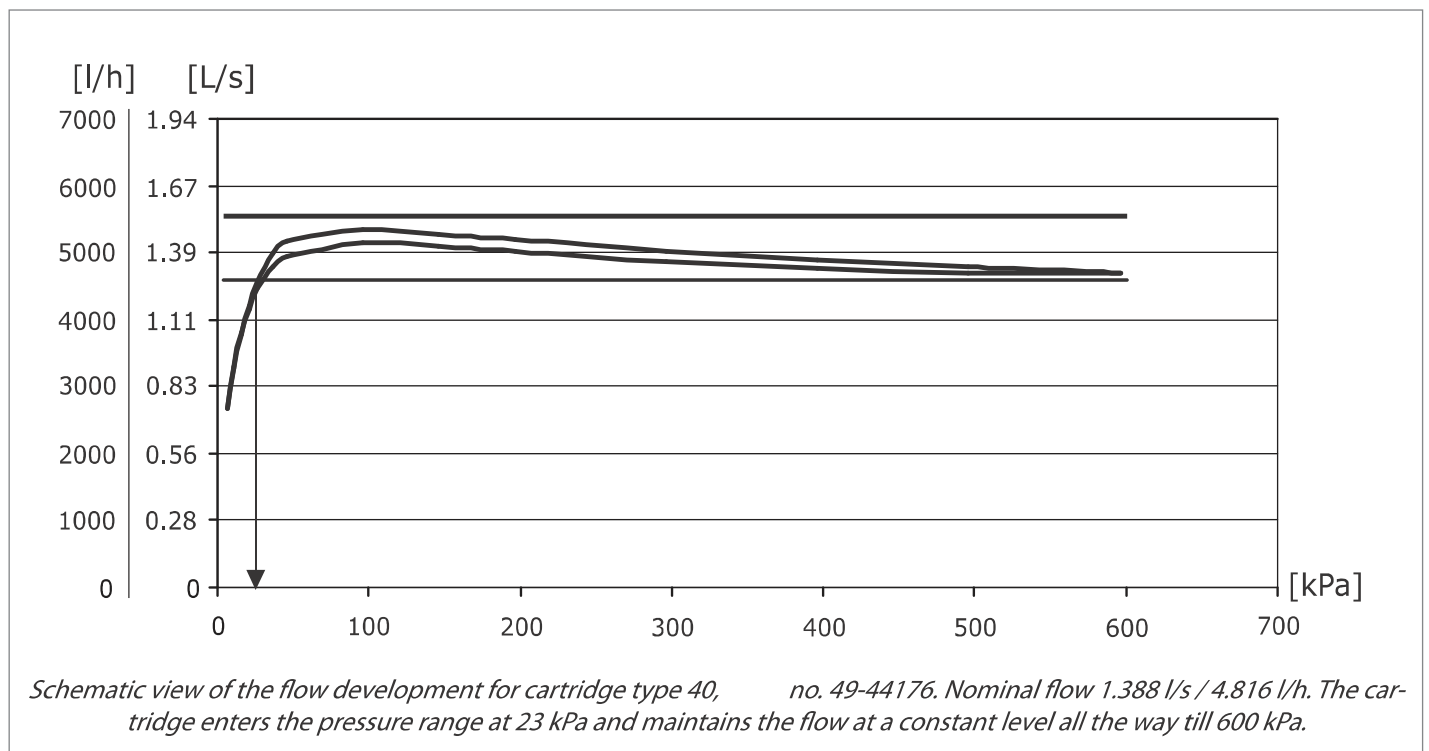
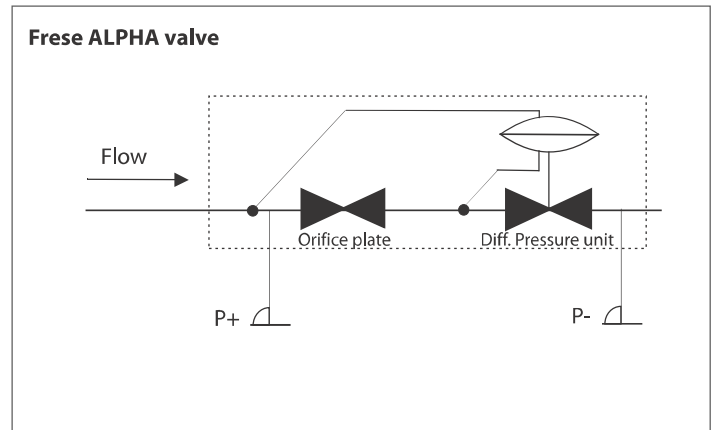

Indication of flow rate on the orifice plate

A four-digit number on the orifice plate is identical with the last four digits in the number. The cartridge can be identified by means of this number and the corresponding flow rate can be read from the above flow rate tables.

High Pressure no.	Flow [gpm]	Flow [l/s]	Min. ΔP [kPa]
49-11740	3.52	0.222	16
49-11745	3.83	0.242	19
49-11750	4.12	0.260	21

49= HP High Pressure
50= Low Pressure

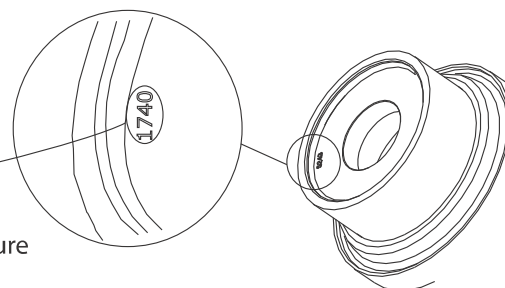

ALPHA Cartridges

Cartridge operation

When the pressure increases the spring will be compressed and thereby the piston will reduce the outlet area and vice versa. The result is a constant flow rate through the valve, independent of pressure fluctuations.

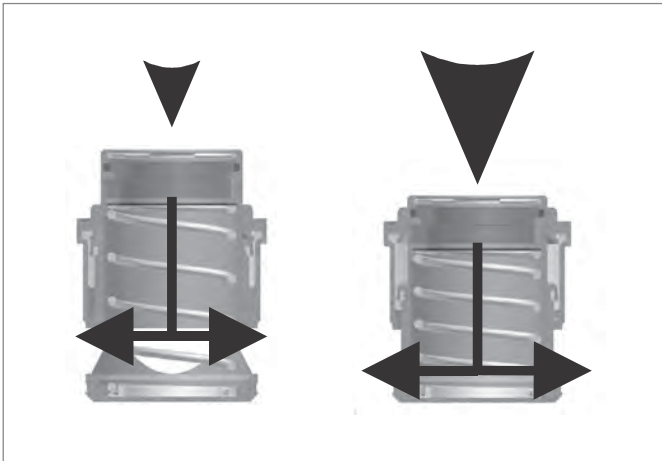

Flow calculation

The flow through the valve can be identified by measuring the differential pressure (Δp) across the valve:

If the measured differential pressure is above the minimum Δp , the flow is the one stated on the graph for the valve.

If the measured differential pressure is below the minimum Δp , the flow can be found by using the formulas below.

Flow Calculation

$Q = K_v \cdot \sqrt{\Delta p}$	$Q = m^3/h$ $\Delta p = \text{Bar}$
$Q = K_v \cdot 100 \cdot \sqrt{\Delta p}$	$Q = l/h$ $\Delta p = \text{kPa}$
$Q = \frac{K_v}{36} \cdot \sqrt{\Delta p}$	$Q = l/s$ $\Delta p = \text{kPa}$

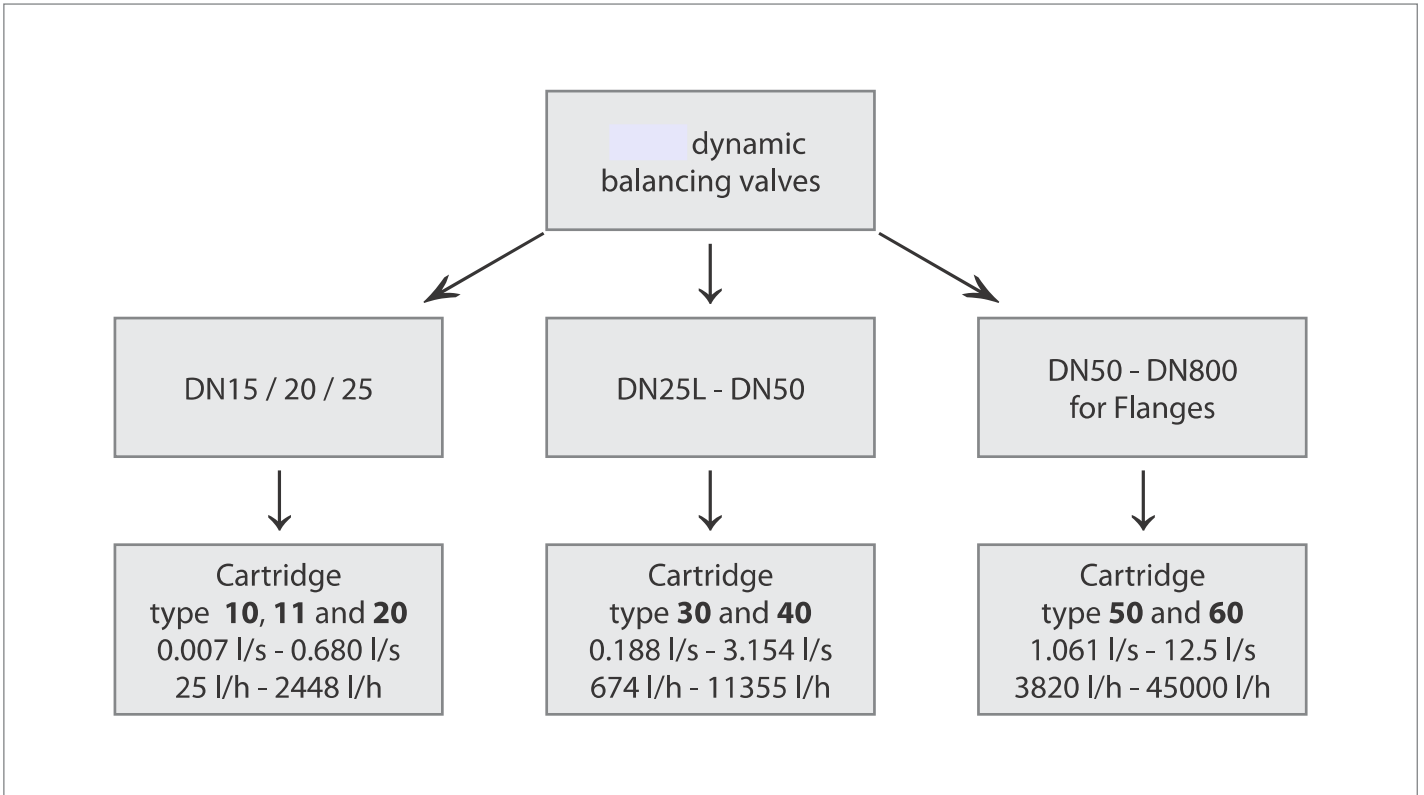



ALPHA Cartridges

Technical data

Cartridge Material:	DZR Brass CW602N (Low pressure cartridges) DZR Brass CW 602N Tin/nickel plated (High pressure cartridges) AISI 304 (Wafer cartridges)
O-rings:	EPDM 281
Spring:	Stainless Steel 1.4310 (Low pressure & High pressure cartridges) AISI 316 (Wafer cartridges)
Diaphragm:	HNBR (Low pressure cartridges) HNBR reinforced (High pressure cartridges)
Medium Temperature:	-20 to + 120°C

Dimensions

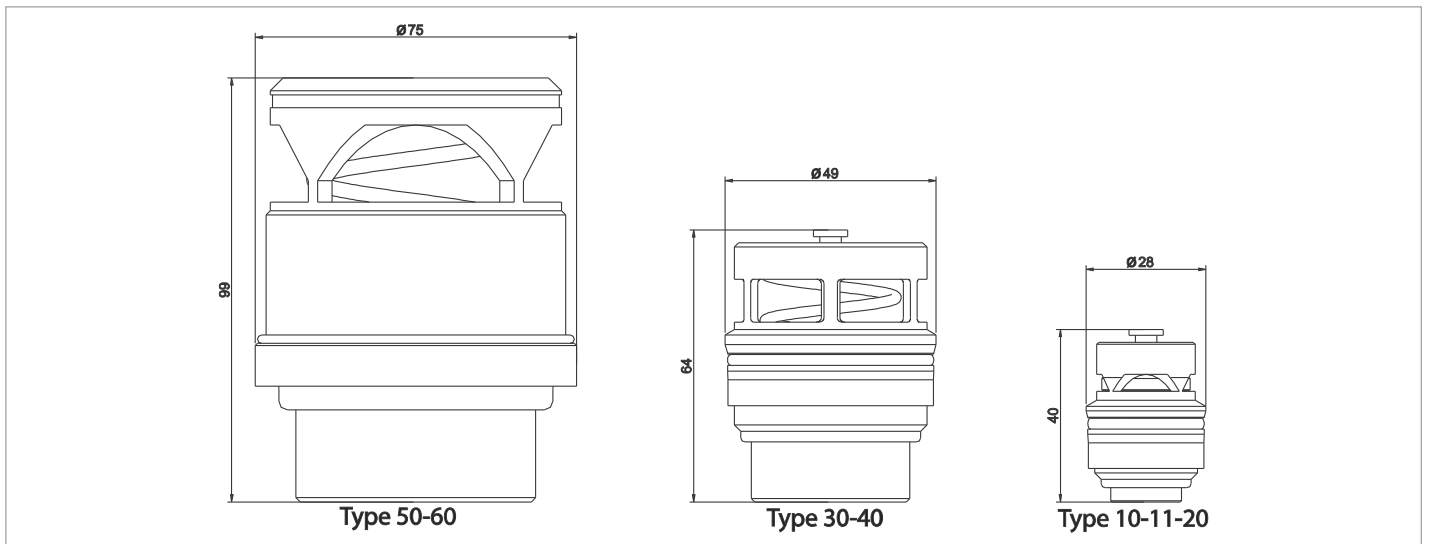

Specification text

High pressure cartridges

DN15 - DN50:

The cartridge (for automatic balancing valve) should be made of tin/nickel plated brass; There should be only one differential pressure control range up to 600kPa; The flow rate should be defined by replaceable orifice plate. The diaphragm should be made of reinforced HNBR, the O-rings should be made of EPDM.

Low pressure cartridges

DN15 - DN50:

The cartridge (for automatic balancing valve) should be made of brass; There should be only one differential pressure control range up to 350kPa; The flow rate should be defined by replaceable orifice plate. The diaphragm should be made of HNBR; the O-rings should be made of EPDM. The cartridge can be identified by means of this number and the corresponding flow rate can be read from the above flow rate tables.

High pressure cartridges

DN50 - DN800:

The cartridge for automatic balancing valve (flanged housing) should be made of stainless steel; There should be only one differential pressure control range up to 600kPa; The flow rate should be defined by replaceable orifice plate. The diaphragm should be made of reinforced HNBR, the O-rings should be made of EPDM.



ALPHA Cartridges

High Pressure no. Max. Δp 600 kPa	Low Pressure no. Max. Δp 350 kPa	Flow [l/h]	Flow [l/s]	Flow [gpm]	Min. ΔP [kPa]	Kv
	50-11150	25	0.007	0.11	7	0,09
	50-11170	36	0.010	0.15	7	0,14
	50-11190	43	0.012	0.20	7	0,16
49-11210	50-11210	55	0.015	0.24	7	0,21
49-11230	50-11230	75	0.021	0.33	8	0,27
49-11260	50-11260	84	0.024	0.39	9	0,28
49-11290	50-11290	104	0.029	0.46	10	0,33
49-11300	50-11300	114	0.032	0.50	10	0,36
49-11320	50-11320	129	0.036	0.57	11	0,39
49-11350	50-11350	154	0.043	0.68	11	0,46
49-11370	50-11370	175	0.049	0.77	12	0,51
49-11400	50-11400	204	0.057	0.90	12	0,59
49-11430	50-11430	241	0.067	1.06	12	0,70
49-11460	50-11460	279	0.078	1.23	12	0,81
49-11490	50-11490	320	0.089	1.41	13	0,89
49-11510	50-11510	350	0.097	1.54	13	0,97
49-11540	50-11540	400	0.111	1.76	13	1,11
49-11570	50-11570	477	0.132	2.10	14	1,27
49-11620	50-11620	545	0.151	2.40	14	1,46
49-11725	50-11725	615	0.171	2.71	14	1,64
49-11730	50-11730	670	0.186	2.95	14	1,79
49-11735	50-11735	736	0.204	3.24	14	1,97
49-11740	50-11740	799	0.222	3.52	16	2,00
49-11745	50-11745	870	0.242	3.83	19	2,00
49-11750	50-11750	936	0.260	4.12	21	2,04
49-20700	50-20700	1020	0.283	4.49	22	2,17
49-20740	50-20740	1081	0.300	4.76	22	2,30
49-20770	50-20770	1195	0.332	5.26	22	2,55
49-20820	50-20820	1335	0.371	5.88	23	2,78
49-20860	50-20860	1483	0.412	6.53	23	3,09
49-20880	50-20880	1581	0.439	6.96	23	3,30
49-20920	50-20920	1774	0.493	7.81	24	3,62
49-20940	50-20940	1833	0.509	8.07	24	3,74
49-20990	50-20990	2080	0.578	9.16	25	4,16
49-21030	50-21030	2251	0.625	9.91	26	4,41
49-21060	50-21060	2319	0.644	10.21	27	4,46
49-21090	50-21090	2448	0.680	10.78	28	4,63

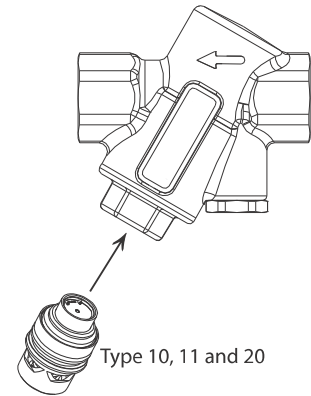



ALPHA Cartridges

High Pressure no. Max. Δp 600 kPa	Low Pressure no. Max. Δp 350 kPa	Flow [l/h]	Flow [l/s]	Flow [gpm]	Min. ΔP [kPa]	Kv
49-33073	50-33073	674	0.188	2.97	12	1,95
49-33082	50-33082	861	0.239	3.79	12	2,49
49-33089	50-33089	1020	0.283	4.49	12	2,94
49-33094	50-33094	1136	0.315	5.00	12	3,28
49-33096	50-33096	1190	0.331	5.24	12	3,44
49-33098	50-33098	1272	0.353	5.60	13	3,53
49-33102	50-33102	1349	0.375	5.94	13	3,74
49-33107	50-33107	1485	0.413	6.54	13	4,12
49-33111	50-33111	1567	0.435	6.90	14	4,19
49-33112	50-33112	1631	0.453	7.18	14	4,36
49-33118	50-33118	1815	0.504	7.99	14	4,85
49-33124	50-33124	2001	0.556	8.81	15	5,17
49-33125	50-33125	2044	0.568	9.00	16	5,11
49-33129	50-33129	2171	0.603	9.56	16	5,43
49-33132	50-33132	2271	0.631	10.00	17	5,51
49-33135	50-33135	2380	0.661	10.48	17	5,77
49-33138	50-33138	2498	0.694	11.00	18	5,89
49-33142	50-33142	2639	0.733	11.62	18	6,22
49-33148	50-33148	2871	0.797	12.64	19	6,59
49-33156	50-33156	3191	0.886	14.05	21	6,96
49-33161	50-33161	3407	0.946	15.00	22	7,26
49-33163	50-33163	3486	0.968	15.35	22	7,43
49-44148	50-44148	3634	1.009	16	20	8,13
49-44152	50-44152	3681	1.023	16	21	8,03
49-44156	50-44156	4088	1.136	18	21	8,92
49-44164	50-44164	4315	1.199	19	21	9,42
49-44168	50-44168	4542	1.262	20	22	9,68
49-44173	50-44173	4769	1.325	21	22	10,17
49-44176	50-44176	4996	1.388	22	23	10,42
49-44182	50-44182	5450	1.514	24	24	11,12
49-44191	50-44191	5905	1.640	26	25	11,81
49-44194	50-44194	6360	1.767	28	26	12,47
49-44200	50-44200	6813	1.893	30	27	13,11
49-44205	50-44205	7267	2.019	32	28	13,73
49-44211	50-44211	7721	2.145	34	30	14,10
49-44217	50-44217	8176	2.271	36	31	14,68
49-44222	50-44222	8630	2.397	38	33	15,02
49-44229	50-44229	9084	2.523	40	34	15,58
49-44235	50-44235	9538	2.650	42	36	15,90
49-44241	50-44241	9990	2.776	44	38	16,21
49-44248	50-44248	10445	2.902	46	40	16,51
49-44250	50-44250	10900	3.028	48	42	16,82
49-44262	50-44262	11355	3.154	50	44	17,12

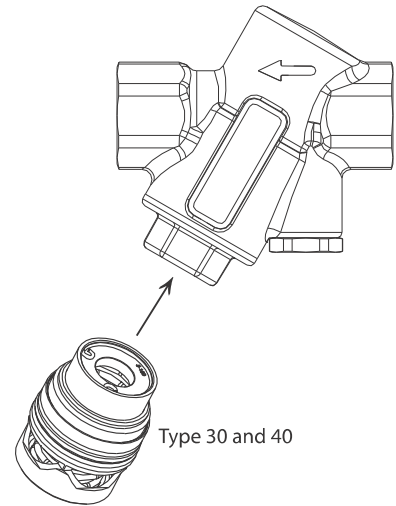

ALPHA Cartridges

AISI 304 no. Max. Δp 600 kPa	Flow [l/h]	Flow [l/s]	Flow [gpm]	Min. ΔP [kPa]	Kv
52-55179	3820	1.061	16.82	13	10,6
52-55184	3931	1.092	17.31	13	10,9
52-55189	4049	1.125	17.83	13	11,2
52-55194	4199	1.167	18.49	13	11,7
52-55200	4399	1.222	19.37	13	12,2
52-55206	4640	1.289	20.43	14	12,4
52-55213	4951	1.375	21.80	14	13,2
52-55220	5310	1.475	23.38	14	14,2
52-55227	5700	1.583	25.10	14	15,2
52-55235	6209	1.725	27.34	14	16,6
52-55243	6511	1.808	28.67	14	17,4
52-55251	7081	1.967	31.18	14	18,9
52-55260	7901	2.194	34.79	15	20,4
52-55269	8900	2.472	39.19	16	22,3
52-55279	10399	2.889	45.79	19	23,9
52-55287	11355	3.154	50.00	22	24,2
52-55292	12491	3.470	55.00	23	26,1
52-55298	13399	3.722	59.00	24	27,4
52-55303	14762	4.100	65.00	27	28,4
52-55308	15999	4.444	70.45	29	29,7
52-66285	17037	4.733	75.02	34	29,2
52-66292	18148	5.041	79.91	34	31,1
52-66301	18797	5.221	82.77	35	31,8
52-66305	19467	5.408	85.72	35	32,9
52-66312	20464	5.684	90.11	35	34,6
52-66319	21527	5.980	94.79	36	35,9
52-66326	22449	6.236	98.85	36	37,4
52-66332	23482	6.523	103.40	36	39,1
52-66338	24531	6.815	108.02	37	40,3
52-66344	25621	7.117	112.82	38	41,6
52-66349	26528	7.369	116.81	38	43,0
52-66356	27686	7.690	121.91	38	44,9
52-66362	29157	8.099	128.39	38	47,3
52-66367	29954	8.320	131.90	39	48,0
52-66373	30976	8.605	136.40	39	49,6
52-66379	32260	8.961	142.05	40	51,0
52-66385	33565	9.324	147.80	40	53,0
52-66391	34953	9.709	153.91	40	55,3
52-66393	36336	10.093	160.00	42	56,1
52-66398	37685	10.468	165.94	43	57,5
52-66400	38607	10.724	170.00	44	58,2
52-66407	40971	11.381	180.41	46	60,4
52-66407H	45000	12.500	198.19	49	64,3

